

# IDC30E

Isolated air-cooling DC charger



## RELIABLE AND SAFE

- IP65 protection and C5 anti-corrosion
- Long lifespan over 10 years
- Carefree maintenance without replacing dust filter mat



## USER FRIENDLY

- Support various options for authentication
- Suitable for C&I and residential usage with EMC Class B
- Environmental friendly with extremely low noise < 50 dB(A)



## EFFICIENT AND SMART

- Max. efficiency up to 96.5%
- Dynamic load management to optimize EV charging



## FLEXIBLE APPLICATION

- Adaptive voltage range 200 - 1000 Vdc

## CIRCUIT DIAGRAM

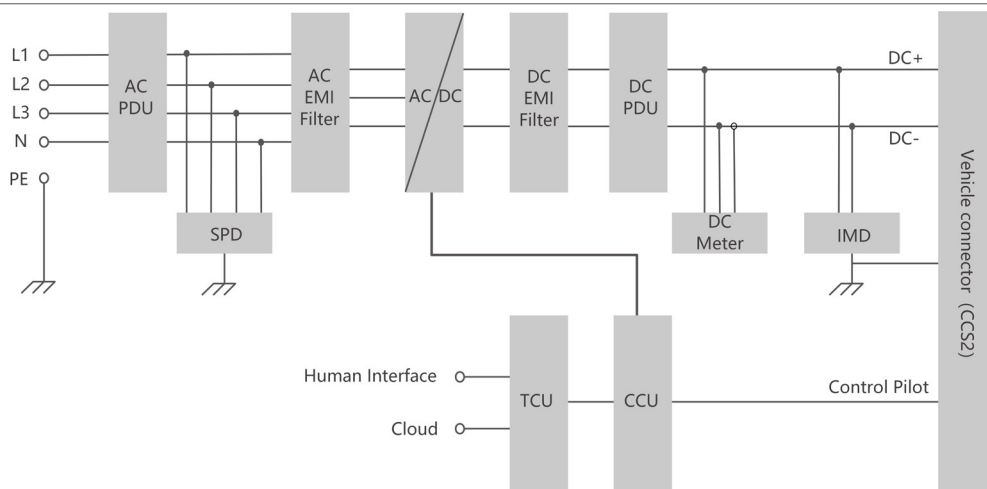

Technical parameters	IDC30E
<b>Charging connector</b>	
Connector type	CCS2
EVSE-vehicle protocol	DIN SPEC 70121
Number of EV served	1
Cable length	5 m
<b>DC Output</b>	
DC output power	30 kW
DC output voltage	200 Vdc - 1000 Vdc
DC output current	80 A
<b>AC Input</b>	
Grid voltage	3 / N / PE, 400 Vac ( ± 10 % )
Nominal grid frequency	50 Hz
Grid frequency range	45 Hz - 55 Hz
Earthing system	TN-C, TN-S, TN-C-S, TT
Rated input current	46 A
Max. input current	52 A
Power factor	≥ 0.99
Total harmonic distortion (THDi)	< 5 % at full output power
Overvoltage category	III
Standby self-consumption	≤ 32 W
<b>Efficiency</b>	
Max. efficiency	96.5%
<b>Protection</b>	
Over / under voltage protection	Yes
Over-current protection	Yes
Short-circuit protection	Yes
Over-temperature protection	Yes
Surge protection	Yes
<b>User interface</b>	
Display	7-inch color touch screen
Language	English ( default ) Other languages available by firmware upgrade
Authentication	RFID-card, Plug & Play, Auto-charge
Firmware update	Over-the-air ( OTA ) by iEnergyCharge
RFID system	ISO / IEC 14443 A / B, ISO / IEC 15693
Energy metering	DC metering ( CE compliant )
Communication interface	4G, Ethernet, WLAN
Communication protocol (charger-to-CSMS)	OCPP 1.6 J Ready for OCPP 2.0.1
Emergency stop	Yes, integrated
<b>Mechanical data</b>	
Dimensions (W*H*D)	500 mm * 800 mm * 242 mm
Weight	53 kg
Installation method	Wall-mounting ( default ) Stand column, trolley ( optional )
Mechanical impact protection	IK10 *
<b>Environmental data</b>	
Degree of protection	IP65
Anti-corrosion degree	C5
Operating ambient temperature range	-35 °C - 55 °C
Allowable relative humidity range	5 % - 95 % ( non-condensing )
Max. operating altitude	≤ 2000 m
Cooling method	Smart forced air cooling
Noise (typical)	≤ 50 dB ( A )
EMC	Class B
<b>Certification and standards</b>	
Certifications	CE, CB, UKCA
Compliance	ETSI / EN 300 328, EN 300 330, EN 301 489-1 / 3 / 17 / 52, ETSI / EN 301 908-1 / 13, EN 50665, BS / EN IEC 61851-1, BS / EN IEC 61851-21-2, BS / IEC EN 61851-23 / 24, EN IEC 62311
Warranty	3 years ( standard )
Country of manufacture	China

\* The mechanical impact protection degree of HMI is IK08