

PV SolarRoof Klip-Lok Interface

Code-Compliant Planning and Installation
Complying with AS/NZS1170.2:2011 AMDT 2-2012



CONTENT

1. Introduction.....	2
2. Component List.....	3
3. Planning.....	4
4. Service.....	13

Introduction

The Eon Solar PV SolarRoof Klip-Lok type interface has been developed as a non-penetrating solution for concealed roofs. The interface can be attached on different type of profiles of concealed roof to mount panels directly or in conjunction with L-feet, tilt legs or SolarTripod.

Please review this manual thoroughly before installing PV Rack SolarRoof. This manual provides (1) supporting documentation for building permit applications relating to PV Rack SolarRoof Universal PV Module Mounting System, and (2) planning and installation instructions.

The Eon Solar PV SolarRoof parts, when installed in accordance with this guide, will be structurally adequate and will meet the AS/NZS1170.2:2011AMDT 2-2012 standard. During installation and especially when working on the roof please comply with the appropriate occupational health and safety regulations. Please also pay attention to other relevant regulations of your local region. Please check that you are using the latest version of the installation manual, which you can do by contacting Eon solar via email on info@eonsolar.com.cn.

Component list

Part name	Picture	Description	Picture
Klip-lok type interface		Tin Interface (L-Feet) with Z-Module	
Inter Clamp		End Clamp	
PV-Rack Standard Rail		Tilt leg Front Foot	
PV-Rack Standard Splice		Tilt leg Back Leg	
SolarTripod Single Suppot		SolarTripod Double Support	
T rail 50		Splice for T rail 50	
M8*25 Hex head bolt			

Planning

The installer is solely responsible for:

- Complying with all applicable local or national building codes and Clean Energy Council guidelines including any that may superseded this manual;
- Ensuring that PV-Rack Solar Roof and other products you use are appropriate for the particular installation and the installation environment;
- Ensuring that the roof, its rafters, connections, and other structural support members can support the array under building live load conditions (this total assembly is hereafter referred to as the roof rafter assembly);
- PV-Rack parts (substitution of parts may void the warranty and invalidate the letter of certification);
- Ensuring that the concealed roof profile installed on the roof have been identified and is one that is accredited and tested
- Ensuring the Klip Lok interface fit strongly to the roofing sheet
- Ensuring safe installation of all electrical aspects of the PV array

This document is designed to support for installations using Eon Solar Klip-Lok type interface and PV-Rack Solar Roof (or SolarTripod) PV Module Mounting System, manufactured by EON SOLAR ENERGY TECH .CO.,LTD. Follow the six steps below and the installation instructions section to install this product in compliance with the AS/NZS1170.2:2011 AMDT 2-2012.

Before proceeding, note the following:

- This document addresses only wind loads on the assumption that wind produces the maximum load factor affecting an installation. Verify that other local factors, such as snow loads and earth quake effects, do not exceed the wind loads. Give precedence to any factor that does. Wind loads are considered to act on the entire projected area, or may be perpendicular to any surface.
- The roof on which the PV-Rack Solar Roof will be installed must have the capacity to resist the combined Design Dead Load and Live Load per footing.
- To determine the parts (Bill of material) you need, you can use our PV-Rack Solar Roof Calculator.

1. Determine the wind region of your installation site

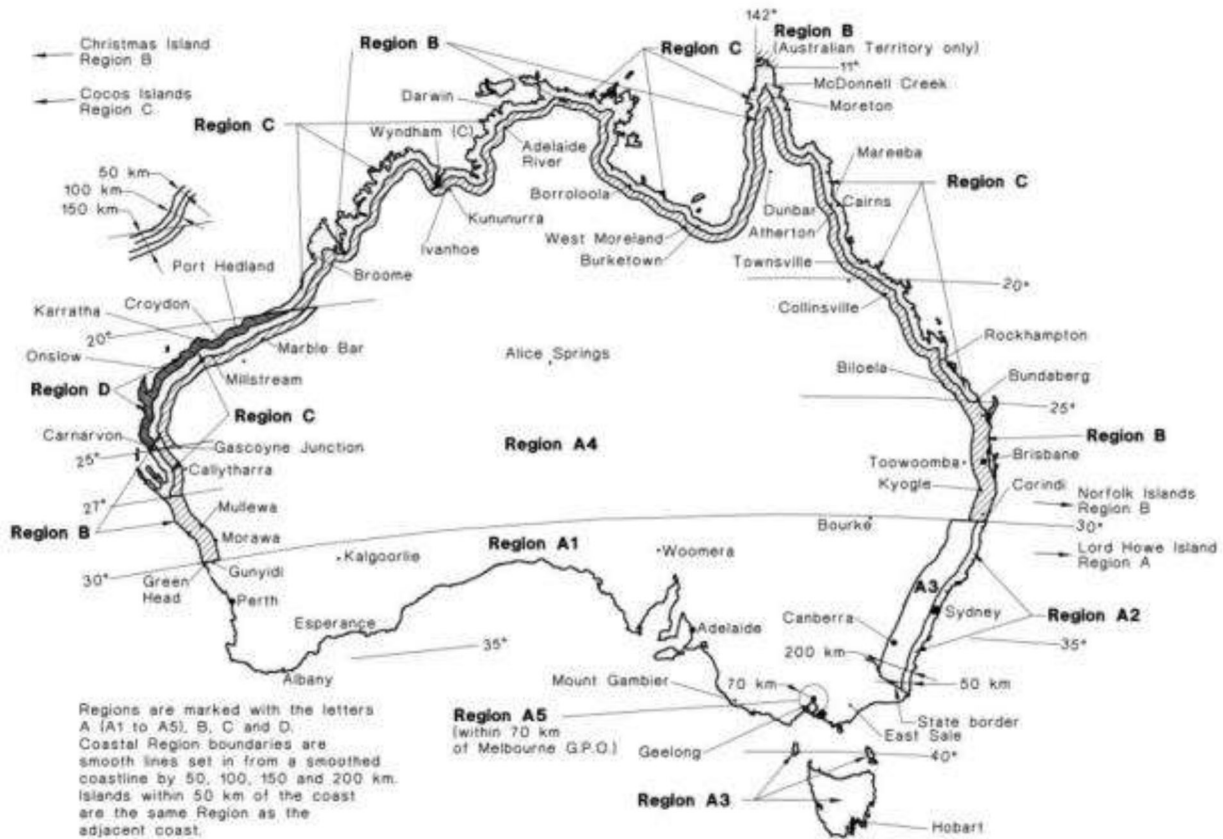

Region Definition:

Wind regions are pre-defined for all of Australia by the Australian Standard 1170.2. The Wind Region is an independent factor of surrounding topography or buildings.

- Most of Australia is designated Region A which indicates a Regional Ultimate Basic Wind Velocity of 45m/s.
- Some areas are designated Region B (57m/s). Local authorities will advise if this applies in your area.
- Region C areas (66m/s) are generally referred to as Cyclonic and are generally limited to northern coastal areas. Most Region C zones end 100km inland.
- Region D (80m/s) Australia's worst Cyclonic Region between Carnarvon and Pardoo in Western Australia.

2. Determine the Terrain Category

You will need to determine the terrain category that is most applicable to the installation.

- Terrain Category 1 (TC1) – Very exposed open terrain with few or no obstructions and enclosed, limited-sized water surfaces at serviceability and ultimate wind speeds in all wind regions, e.g. flat, treeless, poorly grassed plains; rivers, canals and lakes; and enclosed bays extending less than 10km in the wind direction.
- Terrain Category 1.5 (TC1.5) – Open Water surfaces subjected to shoaling waves at serviceability and ultimate wind speeds in all wind regions, e.g. near-shore ocean water; larger unenclosed bays on seas and oceans; lakes; and enclosed bays extending greater than 10km in the wind direction. The terrain height multipliers for this terrain category shall be obtained by the linear interpolation between the values for the TC1 and TC2 in table 4.1.
- Terrain Category 2 (TC2) – Open terrain, including grassland, with well-scattered obstructions having heights generally from 1.5m to 5m, with no more than two obstructions per hectare, e.g. farmland and cleared subdivisions with isolated trees and uncut grass.
- Terrain Category 2.5 (TC2.5) – Terrain with a few trees or isolated obstructions. This category is intermediate between TC2 and TC3 and represents the terrain in developing outer urban areas scattered houses, or larger acreage developments with fewer than ten buildings per hectare. The terrain-height multipliers for this terrain category shall be obtained by linear interpolation between the values for the TC2 and TC3 in table 4.1.
- Terrain Category 3 (TC3) – Terrain with numerous closely spaced obstruction having heights generally from 3m to 10m. The minimum density of obstructions shall be at least the equivalent of 10 house sizes obstructions per hectare, e.g. suburban housing or light industrial estates.
- Terrain Category 4 (TC4) – Terrain with numerous larger, high(10m to 30m tall) and closely-spaced constructions, such as large city centres and well-developed industrial complexes.

Note: In this installation manual we have used terrain category 3, if it is outside of this please refer to the accreditation letter.

3. Determine the type of concealed roof

The best way to identify the type of concealed roof installed is to check the label normally located underneath the roofing sheet.

Otherwise, you can contact the builder or check the building plan to find out the exact type of the roofing sheet.

WARNING! THE USE OF THE KLIP-LOK TYPE BRACKET IS NOT ACCREDITED ON ANY OTHER ROOF TYPES THAN THE FOUR LISTED BELOW.

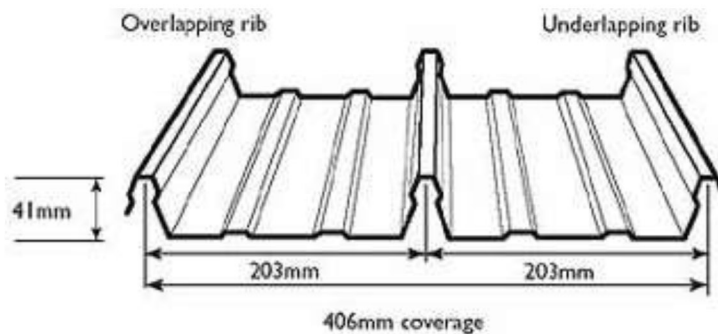
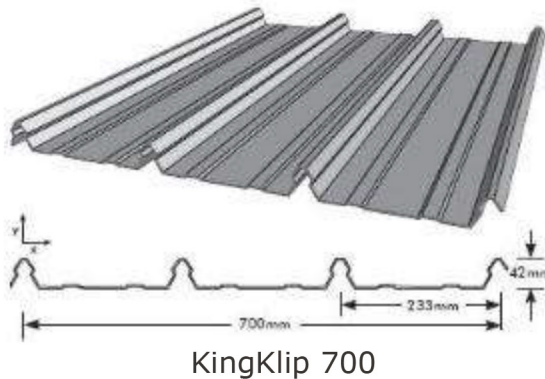
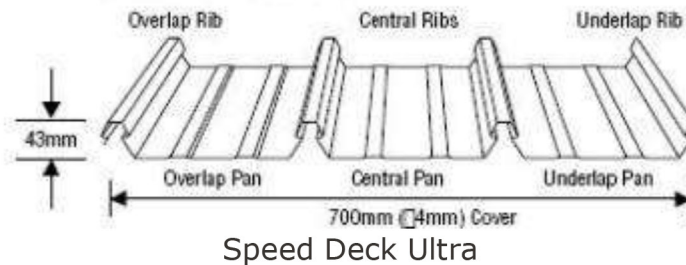
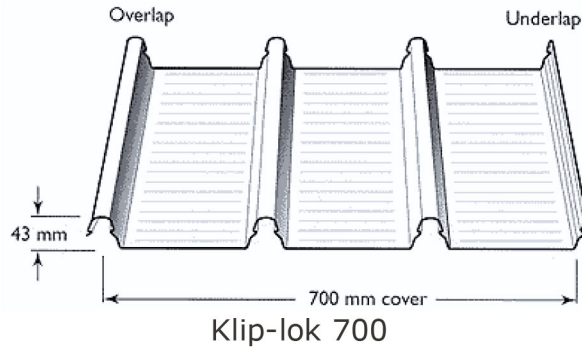

Klip-lok 406

4. Determine the height of your installation site

This document provides sufficient information for the PV-Rack SolarRoof system installation up to 20 meter height. If your installation site is more than 20 meters please contact Eon Solar to obtain additional engineering certificate to support your installation.

5. Determine Roof slope

The PV- Rack SolarRoof system can be used for roof slope up to 60 degrees. Please verify that the Installation site roof slope is between 0 and 60 degrees.

6. Determine the maximum Klip-Lok interface spacing

a) Direct Mounting or using L-feet and rails

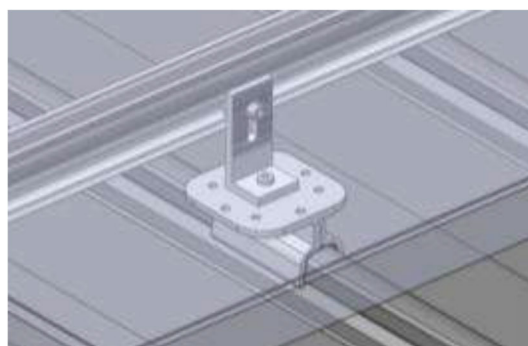
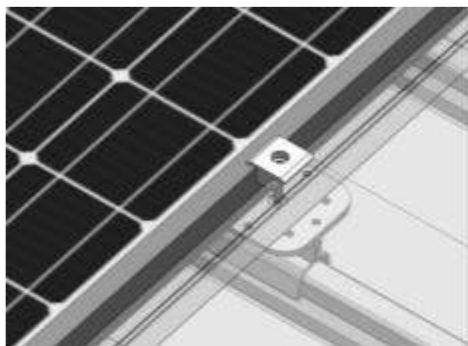

Please use the following table to determine the Maximum Klip-Lok interface spacing (mm).

PV panel length: 1580mm. Max panel weight: **15 kg/m²**. Roof Angle: up to 30°, **Terrain Category 3.**

- On top of the purlin

WIND REGION	A								B							
qu (K Pa)	0.65	0.80	0.75	0.84	0.84	1.02	0.90	1.10	0.83	1.09	0.96	1.26	1.06	1.40	1.14	1.50
hz	5.0 m		10.0 m		15.0 m		20.0 m		5.0 m		10.0 m		15.0 m		20.0 m	
Angle	≤ 15	≤ 30	≤ 15	≤ 30	≤ 15	≤ 30	≤ 15	≤ 30	≤ 15	≤ 30	≤ 15	≤ 30	≤ 15	≤ 30	≤ 15	≤ 30
KlipLok 406	1505	1442	1462	1426	1426	1365	1406	1345	1429	1346	1386	1240	1355	1110	1334	1040
KlipLok 700	1505	1442	1462	1426	1426	1300	1406	1220	1429	1220	1386	1060	1260	950	1170	890
KingKlip 700	880	710	760	680	680	550	630	520	680	520	590	450	540	400	500	380
Stramit SDU	1505	1442	1462	1426	1426	1365	1406	1345	1429	1346	1386	1304	1355	1272	1334	1252
Force (kN/m)	0.57	0.70	0.65	0.73	0.73	0.89	0.78	0.96	0.73	0.96	0.84	1.10	0.93	1.23	0.99	1.21

WIND REGION	C							
qu (Kpa)	1.27	2.19	1.47	2.31	1.63	2.57	1.75	2.75
hz	5.0 m		10.0 m		15.0 m		20.0 m	
Angle	≤ 15	≤ 30	≤ 15	≤ 30	≤ 15	≤ 30	≤ 15	≤ 30
KlipLok 406	1230	710	1060	670	960	600	890	560
KlipLok 700	1050	610	910	570	820	520	760	480
KingKlip 700	450	260	390	240	350	220	320	200
Stramit SDU	1301	940	1259	890	1229	800	1170	740
Force (kN/m)	1.11	1.91	1.28	2.02	1.42	2.25	1.53	2.40

KlipLok Type	Capacity
	kN
Lysaght 406	1.37
Lysaght 700	1.17
Fielders 700	0.5
Stramit SDU	1.8

qu = ultimate wind pressure
Notice, KingKlip is Fielders KlipLok

- Anywhere on the roof

WIND REGION	A								B							
	0.65	0.80	0.75	0.84	0.84	1.02	0.90	1.10	0.83	1.09	0.96	1.26	1.06	1.40	1.14	1.50
	5.0 m		10.0 m		15.0 m		20.0 m		5.0 m		10.0 m		15.0 m		20.0 m	
qu (KPa)	0.65	0.80	0.75	0.84	0.84	1.02	0.90	1.10	0.83	1.09	0.96	1.26	1.06	1.40	1.14	1.50
hz	5.0 m		10.0 m		15.0 m		20.0 m		5.0 m		10.0 m		15.0 m		20.0 m	
Angle	≤ 15	≤ 30	≤ 15	≤ 30	≤ 15	≤ 30	≤ 15	≤ 30	≤ 15	≤ 30	≤ 15	≤ 30	≤ 15	≤ 30	≤ 15	≤ 30
KlipLok 406	700	570	610	540	540	440	510	410	550	410	470	360	430	320	400	300
KlipLok 700	1505	1240	1330	1180	1180	970	1110	900	1190	910	1040	790	940	710	870	660
KingKlip 700	750	610	650	580	580	480	540	440	590	450	510	390	460	350	430	320
Stramit SDU	1280	1040	1110	990	990	810	930	760	1000	760	870	660	780	590	730	550
Force (kN/m)	0.57	0.70	0.65	0.73	0.73	0.89	0.78	0.96	0.73	0.96	0.84	1.10	0.93	1.23	0.99	1.31

WIND REGION	C							
	1.27	2.19	1.47	2.31	1.63	2.57	1.75	2.75
	5.0 m		10.0 m		15.0 m		20.0 m	
qu (Kpa)	1.27	2.19	1.47	2.31	1.63	2.57	1.75	2.75
hz	5.0 m		10.0 m		15.0 m		20.0 m	
Angle	≤ 15	≤ 30	≤ 15	≤ 30	≤ 15	≤ 30	≤ 15	≤ 30
KlipLok 406	360	200	310	190	280	170	260	160
KlipLok 700	780	450	670	430	610	380	560	360
KingKlip 700	380	220	330	210	300	190	280	170
Stramit SDU	650	380	560	360	510	320	470	300
Force (kN/m)	1.11	1.91	1.28	2.02	1.42	2.25	1.53	2.40

KlipLok Type	Capacity kN
Lysaght 406	0.4
Lysaght 700	0.87
Fielders 700	0.43
Stramit SDU	0.73

qu = ultimate wind pressure
Notice, KingKlip is Fielders KlipLok

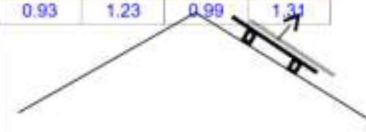

- For PV panel length over 1580mm up to 1700mm reduce the spacing by 6%.
- For PV panel length over 1700mm up to 1800mm reduce the spacing by 11.5%.
- For PV panel length over 1800mm up to 2000mm reduce the spacing by 21%.
- The above table are based on ER-R-ST and ER-I-09 pull out capacity.
- The above table are based on fixing anywhere on the roof including the edges.
- The panels or L-foot have to be fixed using 1 M8 bolt.
- "on purlin" means that the distance from the purlin to the Klip Lok interface (centre to centre) is less than 100mm
- Angle refers to roof angle

b) Using Eon Solar adjustable tilt legs

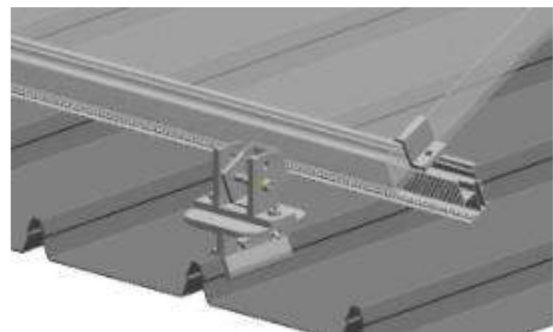
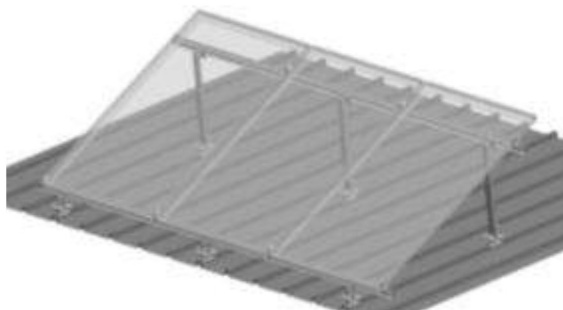

Please use the following table to determine the Maximum Klip-Lok type interface spacing (mm).

PV panel length: 1580mm. Max panel weight: **15 kg/m²**. Tilt Angle: up to 30°, **Terrain Category 3.**

- On top of the purlin

WIND REGION	A								B																							
	0.65		0.80		0.75		0.84		0.84		1.02		0.90		1.10		0.83		1.09		0.96		1.26		1.06		1.40		1.14		1.50	
	5.0 m				10.0 m				15.0 m				20.0 m				5.0 m				10.0 m				15.0 m				20.0 m			
	≤ 15		≤ 30		≤ 15		≤ 30		≤ 15		≤ 30		≤ 15		≤ 30		≤ 15		≤ 30		≤ 15		≤ 30		≤ 15		≤ 30		≤ 15		≤ 30	
KlipLok 406	1505	1442	1462	1426	1426	1365	1400	1140	1429	1346	1386	1240	1355	1110	1334	1040	1429	1346	1386	1240	1355	1110	1334	1040								
KlipLok 700	1505	1442	1462	1426	1426	1300	1200	980	1429	1220	1386	1060	1260	950	1170	890	1429	1220	1386	1060	1260	950	1170	890								
KingKlip 700	880	710	760	680	680	550	510	410	680	520	590	450	540	400	500	380	680	520	590	450	540	400	500	380								
Stramit SDU	1505	1442	1462	1426	1426	1365	1406	1345	1429	1346	1386	1304	1355	1272	1334	1252	1429	1346	1386	1304	1355	1272	1334	1252								
Force (kN/m)	0.57	0.70	0.65	0.73	0.73	0.89	0.97	1.19	0.73	0.96	0.84	1.10	0.93	1.23	0.99	1.31	0.73	0.96	0.84	1.10	0.93	1.23	0.99	1.31								

WIND REGION	C															
	1.27		2.19		1.47		2.31		1.63		2.57		1.75		2.75	
	5.0 m				10.0 m				15.0 m				20.0 m			
	≤ 15		≤ 30		≤ 15		≤ 30		≤ 15		≤ 30		≤ 15		≤ 30	
KlipLok 406	1230	710	1060	670	960	600	600	560	1230	710	1060	670	960	600	600	560
KlipLok 700	1050	610	910	570	820	520	760	480	1050	610	910	570	820	520	760	480
KingKlip 700	450	260	390	240	350	220	320	200	450	260	390	240	350	220	320	200
Stramit SDU	1301	940	1259	890	1229	800	1170	740	1301	940	1259	890	1229	800	1170	740
Force (kN/m)	1.11	1.91	1.28	2.02	1.42	2.25	1.53	2.40	1.11	1.91	1.28	2.02	1.42	2.25	1.53	2.40

KlipLok Type	Capacity kN
Lysaght 406	1.37
Lysaght 700	1.17
Fielders 700	0.5
Stramit SDU	1.8



qu = ultimate wind pressure
Notice, KingKlip is Fielders KlipLok

- Anywhere on the roof

WIND REGION	A								B																							
	0.65		0.80		0.75		0.84		0.84		1.02		0.90		1.10		0.83		1.09		0.96		1.26		1.06		1.40		1.14		1.50	
	5.0 m				10.0 m				15.0 m				20.0 m				5.0 m				10.0 m				15.0 m				20.0 m			
	≤ 15		≤ 30		≤ 15		≤ 30		≤ 15		≤ 30		≤ 15		≤ 30		≤ 15		≤ 30		≤ 15		≤ 30		≤ 15		≤ 30		≤ 15		≤ 30	
KlipLok 406	700	570	610	540	540	440	410	330	550	410	470	360	430	320	400	300	550	410	470	360	430	320	400	300								
KlipLok 700	1505	1240	1330	1180	1180	970	890	720	1190	910	1040	790	940	710	870	660	1190	910	1040	790	940	710	870	660								
KingKlip 700	750	610	650	580	580	480	440	360	590	450	510	390	460	350	430	320	590	450	510	390	460	350	430	320								
Stramit SDU	1280	1040	1110	990	990	810	750	610	1000	760	870	660	780	590	730	550	1000	760	870	660	780	590	730	550								
Force (kN/m)	0.57	0.70	0.65	0.73	0.73	0.89	0.97	1.19	0.73	0.96	0.84	1.10	0.93	1.23	0.99	1.31	0.73	0.96	0.84	1.10	0.93	1.23	0.99	1.31								

WIND REGION	C															
	1.27		2.19		1.47		2.31		1.63		2.57		1.75		2.75	
	5.0 m				10.0 m				15.0 m				20.0 m			
	≤ 15		≤ 30		≤ 15		≤ 30		≤ 15		≤ 30		≤ 15		≤ 30	
KlipLok 406	360	200	310	190	280	170	260	160	360	200	310	190	280	170	260	160
KlipLok 700	780	450	670	430	610	380	560	360	780	450	670	430	610	380	560	360
KingKlip 700	380	220	330	210	300	190	280	170	380	220	330	210	300	190	280	170
Stramit SDU	650	380	560	360	510	320	470	300	650	380	560	360	510	320	470	300
Force (kN/m)	1.11	1.91	1.28	2.02	1.42	2.25	1.53	2.40	1.11	1.91	1.28	2.02	1.42	2.25	1.53	2.40

KlipLok Type	Capacity kN
Lysaght 406	0.4
Lysaght 700	0.87
Fielders 700	0.43
Stramit SDU	0.73



qu = ultimate wind pressure
Notice, KingKlip is Fielders KlipLok

- For PV panel length over 1580mm up to 1700mm reduce the spacing by 6%.
- For PV panel length over 1700mm up to 1800mm reduce the spacing by 11.5%.
- For PV panel length over 1800mm up to 2000mm reduce the spacing by 21%.
- The above table are based on ER-R-ST, ER-I-09 and ER-TL10/15 and 15/30 pull out capacity.
- The above table are based on fixing anywhere on the roof including the edges.
- The feet of the tilt legs have to be fixed using 2 M8 bolt.
- "Angle" refers to the angle between the roof and the panels (not to the horizontal)
- "on purlin" means that the distance from the purlin to the Klip Lok interface (centre to centre) is less than 100mm

c) Using Eon Solar PV- Rack SolarTripod Single

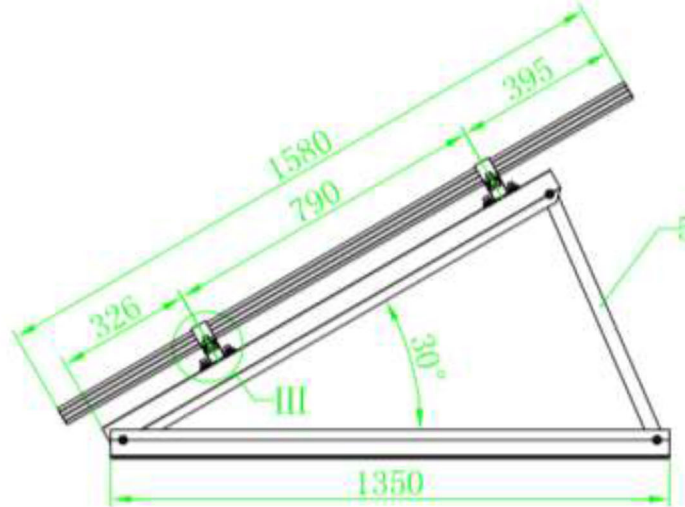

Please use the following table to determine the Maximum Klip-Lok interface spacing (mm).

PV panel length: 1580mm. Max panel weight: **15 kg/m²**. Tilt Angle: up to 30°, **Terrain Category 3**.

- With 2 Klip-Lok interfaces per leg
 - On top of the purlin

WIND REGION	A								B							
	0.65	0.80	0.75	0.84	0.84	1.02	0.90	1.10	0.83	1.09	0.96	1.26	1.06	1.40	1.14	1.50
	5.0 m		10.0 m		15.0 m		20.0 m		5.0 m		10.0 m		15.0 m		20.0 m	
Angle	≤ 15	≤ 30	≤ 15	≤ 30	≤ 15	≤ 30	≤ 15	≤ 30	≤ 15	≤ 30	≤ 15	≤ 30	≤ 15	≤ 30	≤ 15	≤ 30
KlipLok 406	1505	1442	1462	1426	1426	1365	1400	1140	1429	1346	1386	1240	1355	1110	1334	1040
KlipLok 700	1505	1442	1462	1426	1426	1300	1200	980	1429	1220	1386	1060	1260	950	1170	890
KingKlip 700	880	710	760	680	680	550	510	410	680	520	590	450	540	400	500	380
Stramit SDU	1505	1442	1462	1426	1426	1365	1406	1345	1429	1346	1386	1304	1355	1272	1334	1252
Force (kN/m)	0.57	0.70	0.65	0.73	0.73	0.89	0.97	1.19	0.73	0.96	0.84	1.10	0.93	1.23	0.99	1.31

WIND REGION	C							
	1.27	2.19	1.47	2.31	1.83	2.57	1.75	2.75
	5.0 m		10.0 m		15.0 m		20.0 m	
Angle	≤ 15	≤ 30	≤ 15	≤ 30	≤ 15	≤ 30	≤ 15	≤ 30
KlipLok 406	1230	710	1060	670	960	600	600	560
KlipLok 700	1050	610	910	570	820	520	760	480
KingKlip 700	450	260	390	240	350	220	320	200
Stramit SDU	1301	940	1259	890	1229	800	1170	740
Force (kN/m)	1.11	1.91	1.28	2.02	1.42	2.25	1.53	2.40

KlipLok Type	Capacity kN
Lysaght 406	1.37
Lysaght 700	1.17
Fielders 700	0.5
Stramit SDU	1.8

qu = ultimate wind pressure
Notice, KingKlip is Fielders KlipLok



- Anywhere on the roof

WIND REGION	A								B							
	0.65	0.80	0.75	0.84	0.84	1.02	0.90	1.10	0.83	1.09	0.96	1.26	1.06	1.40	1.14	1.50
	5.0 m		10.0 m		15.0 m		20.0 m		5.0 m		10.0 m		15.0 m		20.0 m	
Qu (K Pa)	0.65	0.80	0.75	0.84	0.84	1.02	0.90	1.10	0.83	1.09	0.96	1.26	1.06	1.40	1.14	1.50
h _z	5.0 m		10.0 m		15.0 m		20.0 m		5.0 m		10.0 m		15.0 m		20.0 m	
Angle	≤ 15	≤ 30	≤ 15	≤ 30	≤ 15	≤ 30	≤ 15	≤ 30	≤ 15	≤ 30	≤ 15	≤ 30	≤ 15	≤ 30	≤ 15	≤ 30
KlipLok 406	700	570	610	540	540	440	410	330	550	410	470	360	430	320	400	300
KlipLok 700	1505	1240	1330	1180	1180	970	890	720	1190	910	1040	790	940	710	870	660
KingKlip 700	750	610	650	580	580	480	440	360	590	450	510	390	460	350	430	320
Stramit SDU	1280	1040	1110	990	990	810	750	610	1000	780	870	660	780	590	730	550
Force (kN/m)	0.57	0.70	0.65	0.73	0.73	0.89	0.97	1.19	0.73	0.96	0.84	1.10	0.93	1.23	0.99	1.31

WIND REGION	C							
	1.27	2.19	1.47	2.31	1.63	2.57	1.75	2.75
	5.0 m		10.0 m		15.0 m		20.0 m	
Qu (Kpa)	1.27	2.19	1.47	2.31	1.63	2.57	1.75	2.75
h _z	5.0 m		10.0 m		15.0 m		20.0 m	
Angle	≤ 15	≤ 30	≤ 15	≤ 30	≤ 15	≤ 30	≤ 15	≤ 30
KlipLok 406	360	200	310	190	280	170	260	160
KlipLok 700	780	450	670	430	610	380	560	360
KingKlip 700	380	220	330	210	300	190	280	170
Stramit SDU	650	380	560	360	510	320	470	300
Force (kN/m)	1.11	1.91	1.28	2.02	1.42	2.25	1.53	2.40

KlipLok Type	Capacity kN
Lysaght 406	0.4
Lysaght 700	0.87
Fielders 700	0.43
Stramit SDU	0.73



qu = ultimate wind pressure
Notice, KingKlip is Fielders KlipLok

- With 3 Klip-Lok type interfaces per leg
 - On top of the purlin

WIND REGION	A								B							
	0.65	0.80	0.75	0.84	0.84	1.02	0.90	1.10	0.83	1.09	0.96	1.26	1.06	1.40	1.14	1.50
	5.0 m		10.0 m		15.0 m		40.0 m		5.0 m		10.0 m		15.0 m		20.0 m	
Qu (K Pa)	0.65	0.80	0.75	0.84	0.84	1.02	0.90	1.10	0.83	1.09	0.96	1.26	1.06	1.40	1.14	1.50
h _z	5.0 m		10.0 m		15.0 m		40.0 m		5.0 m		10.0 m		15.0 m		20.0 m	
Angle	≤ 15	≤ 30	≤ 15	≤ 30	≤ 15	≤ 30	≤ 15	≤ 30	≤ 15	≤ 30	≤ 15	≤ 30	≤ 15	≤ 30	≤ 15	≤ 30
KlipLok 406	1505	1442	1462	1426	1426	1365	1406	1345	1429	1346	1386	1304	1355	1272	1334	1252
KlipLok 700	1505	1442	1462	1426	1426	1365	1406	1345	1429	1346	1386	1304	1355	1272	1334	1252
KingKlip 700	1290	1050	1120	1000	1000	820	750	610	1010	770	880	670	790	600	740	560
Stramit SDU	1505	1442	1462	1426	1426	1365	1406	1345	1429	1346	1386	1304	1355	1272	1334	1252
Force (kN/m)	0.38	0.47	0.44	0.50	0.50	0.61	0.66	0.81	0.49	0.65	0.57	0.75	0.63	0.83	0.67	0.89

WIND REGION	C							
	1.27	2.19	1.47	2.31	1.63	2.57	1.75	2.75
	5.0 m		10.0 m		15.0 m		20.0 m	
Qu (Kpa)	1.27	2.19	1.47	2.31	1.63	2.57	1.75	2.75
h _z	5.0 m		10.0 m		15.0 m		20.0 m	
Angle	≤ 15	≤ 30	≤ 15	≤ 30	≤ 15	≤ 30	≤ 15	≤ 30
KlipLok 406	1301	1050	1259	1000	1229	890	1209	840
KlipLok 700	1301	900	1259	850	1210	760	1120	710
KingKlip 700	660	380	570	360	510	320	480	300
Stramit SDU	1301	1148	1259	1133	1229	1105	1209	1087
Force (kN/m)	0.75	1.29	0.87	1.37	0.97	1.52	1.04	1.63

KlipLok Type	Capacity kN
Lysaght 406	1.37
Lysaght 700	1.17
Fielders 700	0.5
Stramit SDU	1.8



qu = ultimate wind pressure
Notice, KingKlip is Fielders KlipLok

- Anywhere on the roof

WIND REGION	A								B							
	0.65	0.80	0.75	0.84	0.84	1.02	0.90	1.10	0.83	1.09	0.96	1.26	1.06	1.40	1.14	1.50
	5.0 m		10.0 m		15.0 m		40.0 m		5.0 m		10.0 m		15.0 m		20.0 m	
Qu (K Pa)	0.65	0.80	0.75	0.84	0.84	1.02	0.90	1.10	0.83	1.09	0.96	1.26	1.06	1.40	1.14	1.50
h _z	5.0 m		10.0 m		15.0 m		40.0 m		5.0 m		10.0 m		15.0 m		20.0 m	
Angle	≤ 15	≤ 30	≤ 15	≤ 30	≤ 15	≤ 30	≤ 15	≤ 30	≤ 15	≤ 30	≤ 15	≤ 30	≤ 15	≤ 30	≤ 15	≤ 30
KlipLok 406	1030	840	900	800	800	650	600	490	810	610	700	530	630	480	590	440
KlipLok 700	1505	1442	1462	1426	1426	1365	1310	1070	1429	1340	1386	1160	1380	1040	1290	970
KingKlip 700	1110	910	970	860	860	700	650	530	870	660	750	570	680	510	630	480
Stramit SDU	1505	1442	1462	1426	1426	1200	1100	900	1429	1120	1280	970	1160	870	1080	810
Force (kN/m)	0.38	0.47	0.44	0.50	0.50	0.61	0.66	0.81	0.49	0.65	0.57	0.75	0.63	0.83	0.67	0.89

WIND REGION	C							
	1.27	2.19	1.47	2.31	1.63	2.57	1.75	2.75
	5.0 m		10.0 m		15.0 m		20.0 m	
Qu (Kpa)	1.27	2.19	1.47	2.31	1.63	2.57	1.75	2.75
h _z	5.0 m		10.0 m		15.0 m		20.0 m	
Angle	≤ 15	≤ 30	≤ 15	≤ 30	≤ 15	≤ 30	≤ 15	≤ 30
KlipLok 406	530	300	460	290	410	260	380	240
KlipLok 700	1150	670	1000	630	900	570	830	530
KingKlip 700	570	330	490	310	440	280	410	260
Stramit SDU	960	560	830	530	750	470	700	440
Force (kN/m)	0.75	1.29	0.87	1.37	0.97	1.52	1.04	1.63

KlipLok Type	Capacity kN
Lysaght 406	0.4
Lysaght 700	0.87
Fielders 700	0.43
Stramit SDU	0.73



qu = ultimate wind pressure
Notice, KingKlip is Fielders KlipLok

- For PV panel length over 1580mm up to 1700mm reduce the spacing by 6%.
- For PV panel length over 1700mm up to 1800mm reduce the spacing by 11.5%.

- For PV panel length over 1800mm up to 2000mm reduce the spacing by 21%.
- The above table are based on ER-R-T50, ER-I-09 and ER-S-TRI/S pull out capacity.
- The last Klip-Lok interface shouldn't be installed closer than 225mm from the end of the tripod leg.
- The above table are based on fixing anywhere on the roof including the edges.
- The base of the tripod have to be fixed using 2 M8 bolt per Klip-Lok type interface
- "Angle" refers to the angle between the roof and the panels (not to the horizontal)
- "on purlin" means that the distance from the purlin to the Klip-Lok interface (centre to centre) is less than 100mm

d) Using Eon Solar PV- Rack SolarTripod Double

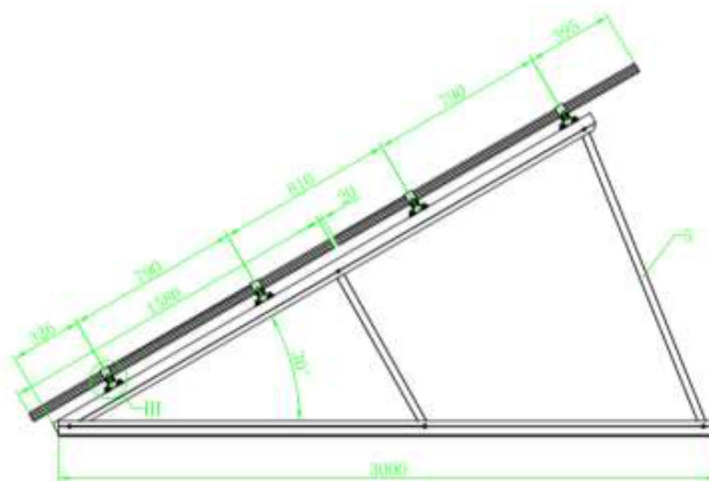

Please use the following table to determine the Maximum Klip-Lok type interface Support Spacing (mm).
 PV panel length: 1580mm. Max panel weight: **15 kg/m²**. Tilt Angle: up to 30°,
Terrain Category 3.

- With 2 Klip-Lok interfaces per leg
 - On top of the purlin

WIND REGION	A																															
	0.65		0.80		0.75		0.84		0.84		1.02		0.90		1.10		0.83		1.09		0.96		1.26		1.06		1.40		1.14		1.50	
	5.0 m		10.0 m		15.0 m		20.0 m		5.0 m		10.0 m		15.0 m		20.0 m		5.0 m		10.0 m		15.0 m		20.0 m		5.0 m		10.0 m		15.0 m		20.0 m	
qu (K Pa)	0.65	0.80	0.75	0.84	0.84	1.02	0.90	1.10	0.83	1.09	0.96	1.26	1.06	1.40	1.14	1.50	0.65	0.80	0.75	0.84	0.84	1.02	0.90	1.10	0.83	1.09	0.96	1.26	1.06	1.40	1.14	1.50
hz	5.0 m		10.0 m		15.0 m		20.0 m		5.0 m		10.0 m		15.0 m		20.0 m		5.0 m		10.0 m		15.0 m		20.0 m		5.0 m		10.0 m		15.0 m		20.0 m	
Angle	≤ 15	≤ 30	≤ 15	≤ 30	≤ 15	≤ 30	≤ 15	≤ 30	≤ 15	≤ 30	≤ 15	≤ 30	≤ 15	≤ 30	≤ 15	≤ 30	≤ 15	≤ 30	≤ 15	≤ 30	≤ 15	≤ 30	≤ 15	≤ 30	≤ 15	≤ 30	≤ 15	≤ 30	≤ 15	≤ 30		
KlipLok 406	1110	900	960	860	860	700	800	660	870	660	750	570	680	510	630	480	1110	900	960	860	860	700	800	660	870	660	750	570	680	510	630	480
KlipLok 700	950	770	820	730	730	600	690	560	740	560	640	490	580	440	540	410	950	770	820	730	730	600	690	560	740	560	640	490	580	440	540	410
KingKlip 700	400	330	350	310	310	N/A	290	N/A	310	240	270	N/A	N/A	N/A	N/A	N/A	400	330	350	310	310	N/A	290	N/A	310	240	270	N/A	N/A	N/A	N/A	N/A
Stramit SDU	1460	1190	1270	1130	1130	920	1060	860	1140	870	990	750	890	670	830	630	1460	1190	1270	1130	1130	920	1060	860	1140	870	990	750	890	670	830	630
Force (kN/m)	1.23	1.51	1.41	1.59	1.58	1.94	1.69	2.07	1.57	2.07	1.81	2.38	2.00	2.65	2.15	2.84	1.23	1.51	1.41	1.59	1.58	1.94	1.69	2.07	1.57	2.07	1.81	2.38	2.00	2.65	2.15	2.84

WIND REGION	C															
	1.27		2.19		1.47		2.31		1.63		2.57		1.75		2.75	
	5.0 m		10.0 m		15.0 m		20.0 m		5.0 m		10.0 m		15.0 m		20.0 m	
qu (Kpa)	1.27	2.19	1.47	2.31	1.63	2.57	1.75	2.75	1.27	2.19	1.47	2.31	1.63	2.57	1.75	2.75
hz	5.0 m		10.0 m		15.0 m		20.0 m		5.0 m		10.0 m		15.0 m		20.0 m	
Angle	≤ 15	≤ 30	≤ 15	≤ 30	≤ 15	≤ 30	≤ 15	≤ 30	≤ 15	≤ 30	≤ 15	≤ 30	≤ 15	≤ 30	≤ 15	≤ 30
KlipLok 406	570	330	490	310	440	280	410	260	570	330	490	310	440	280	410	260
KlipLok 700	480	280	420	260	370	N/A	350	N/A	480	280	420	260	370	N/A	350	N/A
KingKlip 700	N/A	N/A	N/A	N/A	N/A	N/A	N/A	N/A	N/A	N/A	N/A	N/A	N/A	N/A	N/A	N/A
Stramit SDU	740	430	640	410	580	360	540	340	740	430	640	410	580	360	540	340
Force (kN/m)	2.40	4.13	2.77	4.37	3.08	4.86	3.32	5.21	2.40	4.13	2.77	4.37	3.08	4.86	3.32	5.21

KlipLok Type	Capacity kN
Lysaght 406	1.37
Lysaght 700	1.17
Fielders 700	0.5
Stramit SDU	1.8

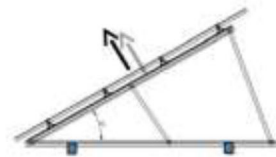

qu = ultimate wind pressure
 Notice, KingKlip is Fielders KlipLok

- Anywhere on the roof

Not suitable

- With 3 Klip-Lok interfaces per leg
 - On top of the purlin

WIND REGION	A								B							
qu (K Pa)	0.65	0.80	0.75	0.84	0.84	1.02	0.90	1.10	0.83	1.09	0.96	1.26	1.06	1.40	1.14	1.50
hz	5.0 m		10.0 m		15.0 m		20.0 m		5.0 m		10.0 m		15.0 m		20.0 m	
Angle	≤ 15	≤ 30	≤ 15	≤ 30	≤ 15	≤ 30	≤ 15	≤ 30	≤ 15	≤ 30	≤ 15	≤ 30	≤ 15	≤ 30	≤ 15	≤ 30
KlipLok 406	1505	1330	1420	1270	1270	1040	1190	970	1280	970	1110	840	1000	760	930	710
KlipLok 700	1400	1140	1220	1080	1080	890	1010	830	1090	830	950	720	860	650	800	600
KingKlip 700	600	480	520	460	460	380	430	350	460	350	400	300	360	270	340	250
Stramit SDU	1505	1442	1462	1426	1426	1365	1406	1270	1400	1280	1460	1110	1320	1000	1230	930
Force (kN/m)	0.83	1.02	0.96	1.07	1.07	1.31	1.15	1.41	1.07	1.40	1.23	1.61	1.36	1.80	1.46	1.93

WIND REGION	C							
qu (Kpa)	1.27	2.19	1.47	2.31	1.63	2.57	1.75	2.75
hz	5.0 m		10.0 m		15.0 m		20.0 m	
Angle	≤ 15	≤ 30	≤ 15	≤ 30	≤ 15	≤ 30	≤ 15	≤ 30
KlipLok 406	840	480	720	460	650	410	600	380
KlipLok 700	710	410	620	390	550	350	520	330
KingKlip 700	300	N/A	260	N/A	N/A	N/A	N/A	N/A
Stramit SDU	1000	640	950	600	860	540	800	500
Force (kN/m)	1.63	2.80	1.88	2.96	2.09	3.30	2.25	3.53

KlipLok Type	Capacity kN
Lysaght 406	1.37
Lysaght 700	1.17
Fielders 700	0.5
Stramit SDU	1.8



qu = ultimate wind pressure
Notice, KingKlip is Fielders KlipLok

- Anywhere on the roof

WIND REGION	A								B							
qu (K Pa)	0.65	0.80	0.75	0.84	0.84	1.02	0.90	1.10	0.83	1.09	0.96	1.26	1.06	1.40	1.14	1.50
hz	5.0 m		10.0 m		15.0 m		20.0 m		5.0 m		10.0 m		15.0 m		20.0 m	
Angle	≤ 15	≤ 30	≤ 15	≤ 30	≤ 15	≤ 30	≤ 15	≤ 30	≤ 15	≤ 30	≤ 15	≤ 30	≤ 15	≤ 30	≤ 15	≤ 30
KlipLok 406	480	390	410	370	370	300	340	280	370	280	320	N/A	290	N/A	270	N/A
KlipLok 700	1040	850	900	800	800	660	750	610	810	620	700	530	640	480	590	450
KingKlip 700	510	420	440	400	400	320	370	300	400	300	350	260	310	N/A	290	N/A
Stramit SDU	870	710	760	670	670	550	630	510	680	520	590	450	530	400	500	370
Force (kN/m)	0.83	1.02	0.96	1.07	1.07	1.31	1.15	1.41	1.07	1.40	1.23	1.61	1.36	1.80	1.46	1.93

WIND REGION	C							
qu (Kpa)	1.27	2.19	1.47	2.31	1.63	2.57	1.75	2.75
hz	5.0 m		10.0 m		15.0 m		20.0 m	
Angle	≤ 15	≤ 30	≤ 15	≤ 30	≤ 15	≤ 30	≤ 15	≤ 30
KlipLok 406	N/A	N/A	N/A	N/A	N/A	N/A	N/A	N/A
KlipLok 700	530	310	460	290	410	260	380	N/A
KingKlip 700	260	N/A	N/A	N/A	N/A	N/A	N/A	N/A
Stramit SDU	440	260	380	N/A	340	N/A	320	N/A
Force (kN/m)	1.63	2.80	1.88	2.96	2.09	3.30	2.25	3.53

KlipLok Type	Capacity kN
Lysaght 406	0.4
Lysaght 700	0.87
Fielders 700	0.43
Stramit SDU	0.73

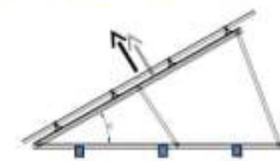

qu = ultimate wind pressure
Notice, KingKlip is Fielders KlipLok

- For PV panel length over 1580mm up to 1700mm reduce the spacing by 6%.
- For PV panel length over 1700mm up to 1800mm reduce the spacing by 11.5%.

- For PV panel length over 1800mm up to 2000mm reduce the spacing by 21%.
- The above table are based on ER-R-T50, ER-I-09 and ER-S-TRI/S pull out capacity.
- The last Klip-Lok type interface shouldn't be installed closer than 500mm from the end of the tripod leg.
- The above table are based on fixing anywhere on the roof including the edges.
- The base of the tripod has to be fixed using 2 M8 bolt per Klip-Lok type interface.
- "Angle" refers to the angle between the roof and the panels (not to the horizontal)
- "on purlin" means that the distance from the purlin to the Klip Lok interface (centre to centre) is less than 100mm

1. Service

10 year limited Product Warranty, 5 year limited Finish Warranty

EON SOLAR ENERGY TECH.CO.,LTD. warrants to the original purchaser("Purchaser") of product(s) that it manufactures ("Product") at the original installation site that the Product shall be free from defects in material and workmanship for a period of ten (10) years, except for the anodised finish, which finish shall be free from visible peeling, or cracking or chalking under normal atmospheric conditions for a period of five (5) years, from the earlier of 1) the date the installation of the Product is completed, or 2) 30 days after the purchase of the Product by the original Purchaser ("Finish Warranty").

The Finish Warranty does not apply to any foreign residue deposited on the finish. All installations in corrosive atmospheric conditions are excluded. The Finish Warranty is VOID if the practices specified by AAMA 609 & 610-02 – "Cleaning and Maintenance for Architecturally Finished Aluminium" (www.aamanet.org) are not followed by Purchaser. This Warranty does not cover damage to the Product that occurs during its shipment, storage, or installation.

This Warranty shall be VOID if installation of the Product is not performed in accordance with Eon Solar's written installation instructions, or if the Product has been modified, repaired, or reworked in a manner not previously authorized by Eon Solar IN WRITING, or if the Product is installed in an environment for which it was not designed. Eon Solar shall not be liable for consequential, contingent or incidental damages arising out of the use of the Product by Purchaser under any circumstances.

If within the specified Warranty periods the Product shall be reasonably proven to be defective, then Eon Solar shall repair or replace the defective Product, or any part thereof, in Eon Solar's sole discretion. Such repair or replacement shall completely satisfy and discharge all of Eon Solar's liability with respect to this limited Warranty. Under no circumstances shall Eon Solar be liable for special, indirect or consequential damages arising out of or related to use by Purchaser of the Product.

Manufacturers of related items, such as PV modules and flashings, may provide written warranties of their own. Eon Solar's limited Warranty covers only its Product, and not any related items.