

Quick Installation Guide

SG2K-S / SG2K5-S / SG3K-S / SG3K-D / SG5K-D

PV Grid-Connected Inverter



This guide is valid for inverters SG2K-S, SG2K5-S, SG3K-S, SG3K-D and SG5K-D, providing the installation, electrical connection, commissioning and troubleshooting procedure.

NOTICE

- In no case shall this guide substitute for the user manual or related notes on the device.
- Make sure to read over, fully understand and strictly follow the detailed instructions of the user manual and other related regulations.
- Any violation could result in personal death or injury or device damage.

1 Preparation

1.1 Cable requirements

Cable	Type	Cross Section (mm ²)		Cable diameter (mm)	
		Range	Recommended Value	Range	Recommended Value
AC cable	SG2K-S / SG2K5-S / SG3K-S / SG3K-D	4...6	4	10...14	14
	SG5K-D	4...6	6	10...14	14
PV cable	All	4...6	-	6...9	-
PE cable	All	10 (copper wire) or 16 (aluminum wire)		-	-

NOTICE

- The PV cables must have multi-stranded wires.

2 Installation

Step 1 Turn the DC switch to OFF, then disconnect the AC circuit breaker and secure it against reconnection.

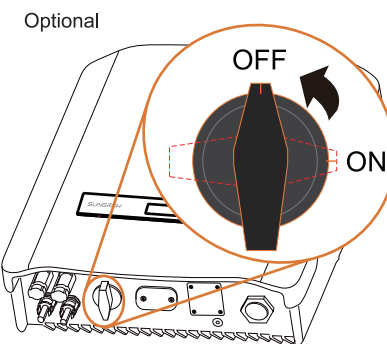

* Image shown here is for reference only. Actual product you receive may differ.

Step 2 Fasten the bracket to the wall with the expansion plug sets.

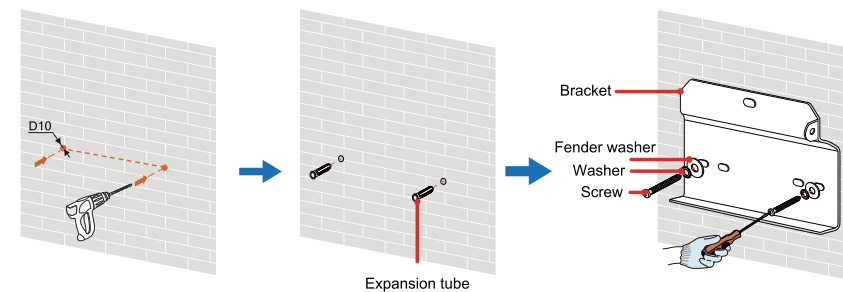

Note:

- The expansion plug sets are not included in the delivery contents.
- Drill the hole with a Φ10 drill bit.
- The depth of the holes should be about 70 mm.

Step 3 Hang the inverter onto the bracket and secure it with the screw (torque 1.5 N.m).

Note:

- Take enough space for convection into consideration during installation.
- The minimum space from the bottom is 800 mm if the communication module is equipped.

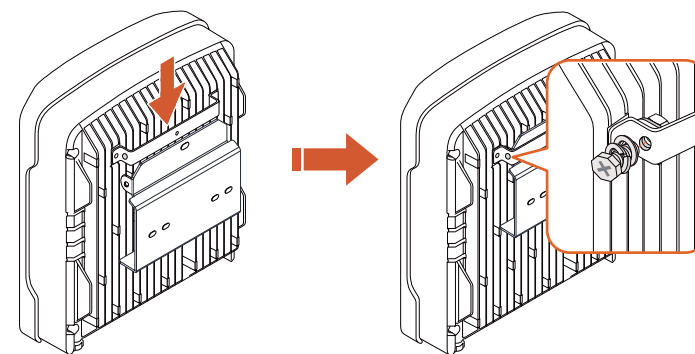

Step 4 To protect the inverter from theft, you can lock it with a padlock. The padlock is purchased by the user if necessary. The hole diameter is about 8 mm.

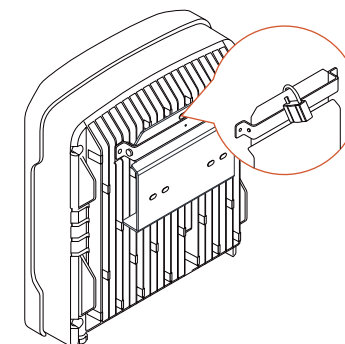

Step 5 Plug the Wi-Fi module into the RS485 terminal and fasten the screws with appropriate torque. Slightly shake it to determine whether it is installed firmly.

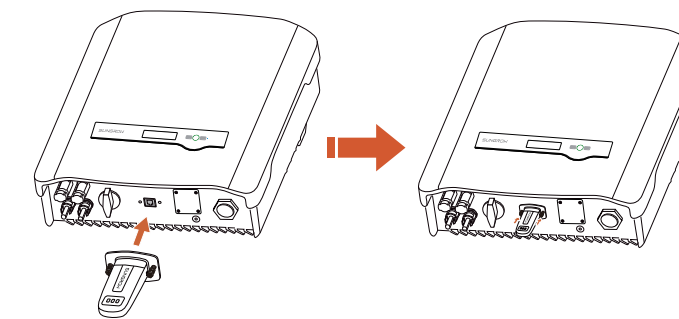

NOTICE

The RS485 terminal can also be used to connect an external RS485 device. For the pin definition and waterproof procedure, please contact SUNGROW. Failure to comply with the requirements of wiring or waterproof will void the warranty.

3 Cable Connection

Step 1 A second PE terminal is equipped at the bottom of the inverter. Be sure to connect the PE terminal for reliable grounding.

No.	Description
1	PV input terminals (1 or 2 pairs)
2	RS485 terminal
3	Meter DRM terminals
4	Second PE terminal
5	AC output to the grid

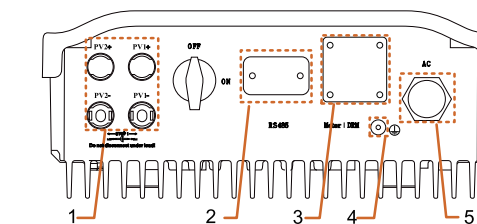

No.	Description	Remark
A	Screw	M4 x 10 mm
B	Spring washer	-
C	Washer	-
D	Cable socket	-
E	Yellow-green cable	10 mm ² (copper wire) or 16 mm ² (aluminum wire)

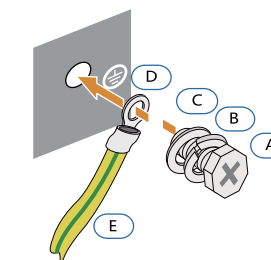

NOTICE

In no case shall the second PE connection substitute for the PE connection in the AC terminal block. Be sure to connect both PE terminals for reliable grounding. The loss of any or all rights may follow if otherwise.

Step 2 Assemble the AC plug-in connector. Align the AC connector and the AC terminal and mate them together by hand until a "Click" is heard or felt.

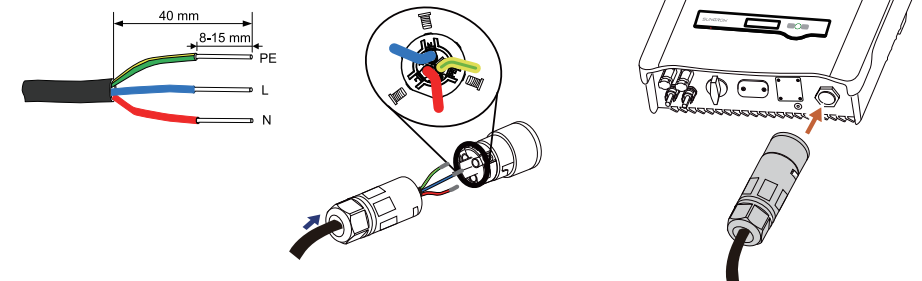

Step 3 Assemble the PV plug-in connectors, and then plug into the corresponding terminals until there is an audible click.

The inverter will not function properly if the PV polarities are reversed. If the PV connectors are not assembled into place, it may cause an arc or overheat. The loss caused by this issue will void the warranty.

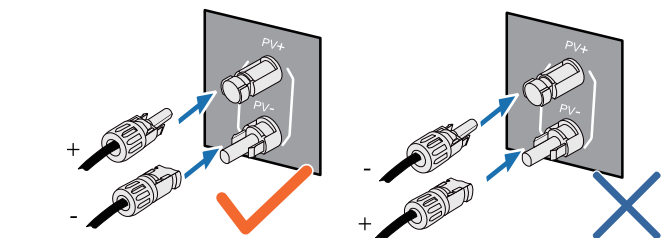

For -S series, only one input can be connected.
For -D series, the two PV inputs can be configured in independent mode or parallel mode.

i

- For independent mode, the two PV inputs work independently, each with its own MPPT. Therefore the two PV inputs can be different from each other in PV module types, numbers of PV panels in a PV string, tilt angles and orientation angle of PV modules.
- For parallel mode, all PV strings with the same type, the same number of PV panels, identical tilt and identical orientation in series can be connected to the same single input area. Two strings in parallel can connect to a DC isolator and then split into two cables which connect to each PV input.

Step 4 (Optional) Meter's RS485 connection. Lead the A and B plugs from inside out through the connector. This will result in the cable with the RJ45 plug on the inside end, and the A and B plugs on the outside. Insert the RJ45 plug into the left (Meter) port until it makes a clicking sound. The connector is delivered with the inverter and the cable is delivered with the meter.

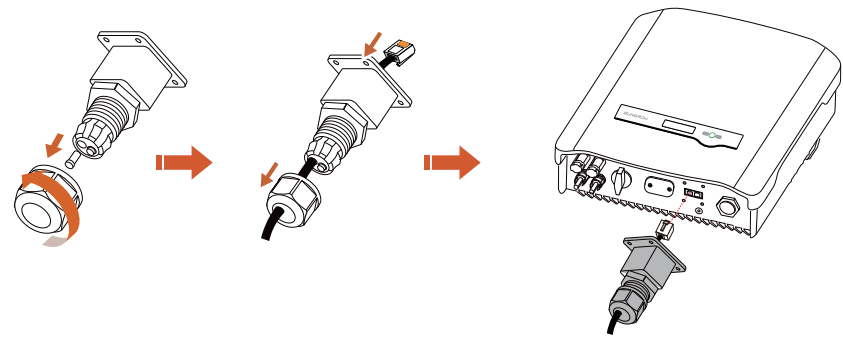

Step 5 Assemble the RJ45 plug for DRM communication, then plug into the DRM terminal until there is an audible click. Secure the waterproof lid to the inverter bottom with four screws and then fasten the swivel nut.

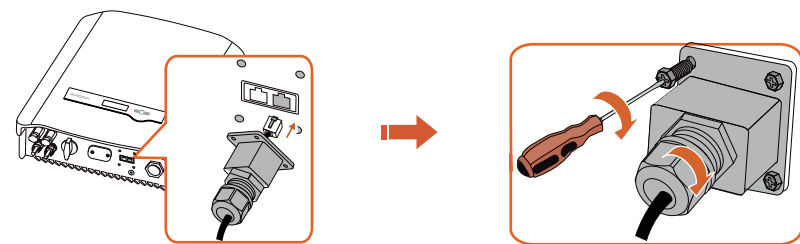

3 Commissioning

3.1 Inspection before Commissioning

Before starting up the inverter for the first time, you should check the following items:

No.	Content	State	
		Yes	No
1	The inverter is accessible for operation, maintenance and service.	<input type="checkbox"/>	<input type="checkbox"/>
2	Re-check if the inverter is firmly secured.	<input type="checkbox"/>	<input type="checkbox"/>
3	Well ventilation is provided and nothing is left on top of the inverter.	<input type="checkbox"/>	<input type="checkbox"/>
4	The inverter and accessories are correctly connected.	<input type="checkbox"/>	<input type="checkbox"/>
5	Cables are properly routed and protected against mechanical damage.	<input type="checkbox"/>	<input type="checkbox"/>
6	The specification of the AC circuit breaker is reasonable.	<input type="checkbox"/>	<input type="checkbox"/>
7	Terminals unused underneath the inverter are sealed.	<input type="checkbox"/>	<input type="checkbox"/>
8	All warning signs and labels are suitably affixed and clearly visible.	<input type="checkbox"/>	<input type="checkbox"/>

3.2 Button Function

The LCD display panel with a screen, an indicator and two buttons is on the front of the inverter. The buttons have multiple functions. Please refer to the following table before any operation of the inverter.

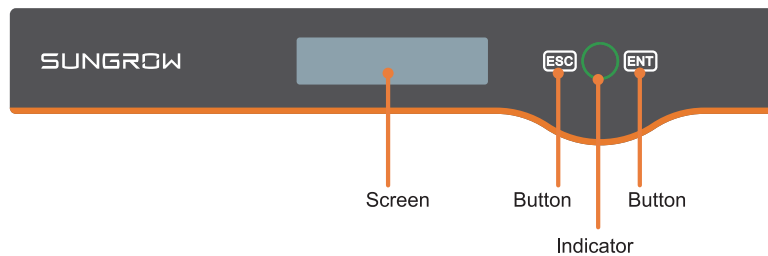

Button	Operation	Description
ESC	≤ 1.2 s	Navigate up / down or change the setting values. Hereinafter referred to as "Touch ESC".
	> 1.2 s	Return to a previous menu or cancel the settings. Hereinafter referred to as "Press ESC".
ENT	≤ 1.2 s	Move left or right, or turn pages, or view the active error/warning from the main screen. Hereinafter referred to as "Touch ENT".
	> 1.2 s	Enter the sub-menu or confirm a selection or settings. Hereinafter referred to as "Press ENT".

NOTICE

DO not touch the hot parts (such as heat sink) during operation. Only the buttons and the optional DC switch can be touched.

3.3 Commissioning Procedure

- Step 1 Make sure all the items mentioned above meet the requirements.
- Step 2 Connect the external AC circuit breaker.
- Step 3 Rotate the optional DC switch to "ON". If there is sufficient sunlight, the inverter will enter the running state and start to feed AC power to the grid.
- Step 4 Observe the status of the LED indicator.

LED Status	Description	
Green	Steady on	The inverter is running normally, or with a warning, or with power limitation.
	Blinking once every 1 s	In the status of standby, or start up, or off via LCD.

LED Status	Description	
Red	Steady on	Inverter fault.
	Blinking once every 0.2 s	Grid fault.
Orange	Blinking once every 1 s	PV fault.
	Steady on	In the status of upgrading.

Step 5 Find the fault codes.

If the LED indicator is blinking red, there are two methods to check the state and find the error codes.

Method 1 (Inverter screen):

The current error code will be displayed on the main screen.

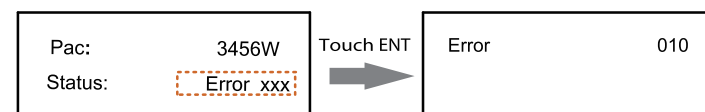

Proceed as follows to view the error record.

Main Screen (Press ENT) → Menu (Touch ESC × 3) → Error Record (Press ENT)

Scroll pages by touching ENT / ESC

Press ESC to exit.

No.	Time	Error Code
1	15/01/21 09:10:12	P1/7 010
2	15/01/21 09:10:08	004
3	15/01/21 09:11:08	005

Tab. 3-2 Description of status on the main screen

State	Description
Running	After being energized, the inverter tracks the PV array's maximum power point (MPP) and feeds the AC power to grid. This mode is the normal mode.
Startup	The inverter is initializing and synchronizing with the grid.
Standby	The inverter waits for sufficient sunlight, then the DC voltage recovers.
Error xxx	If an error occurs, the inverter will automatically stop operation, trigger the AC relay and show "Error xxx" on the LCD with the circle indicating red (xxx is the error code). Once the error is cleared in recovery time, the inverter will automatically resume running.
Turn off	The inverter will stop running by manual "OFF" through the LCD menu or with the DRM0 command from external DRED. Set to "ON" if you want to restart the inverter.
Upgrading	The DSP or LCD program is upgrading.

Method 2 (SolarInfo Home App):

If you have installed the Wi-Fi module, please connect to the inverter's Wi-Fi network started with SG- via a smart phone and then click "Direct Visit" to login.

When an error occurs, the icon will automatically display on any software interface. Click the icon to view detailed information.



4 LCD Operation

4.1 Main Menu

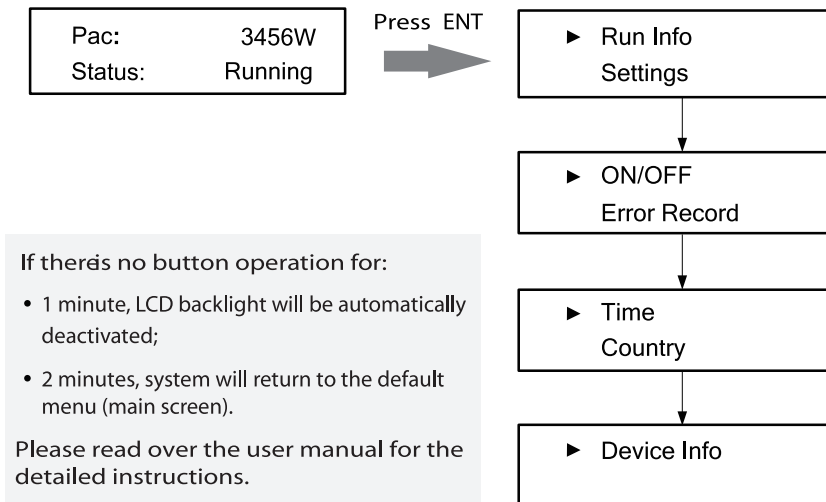

- If there's no button operation for:
- 1 minute, LCD backlight will be automatically deactivated;
 - 2 minutes, system will return to the default menu (main screen).

Please read over the user manual for the detailed instructions.

When there is no button operation for 8 seconds on the main screen, the LCD screen will automatically display through the main screen and energy, PV and grid interfaces, with each interface stayed for 2 seconds. Quit this mode by any operation on any button.

4.2 Advanced Settings

NOTICE

Only qualified personnel are permitted to set the protection parameters.

The parameter settings are protected with a password.

Main Screen (Press ENT) → Menu (Press ESC × 1) → Settings (Press ENT)

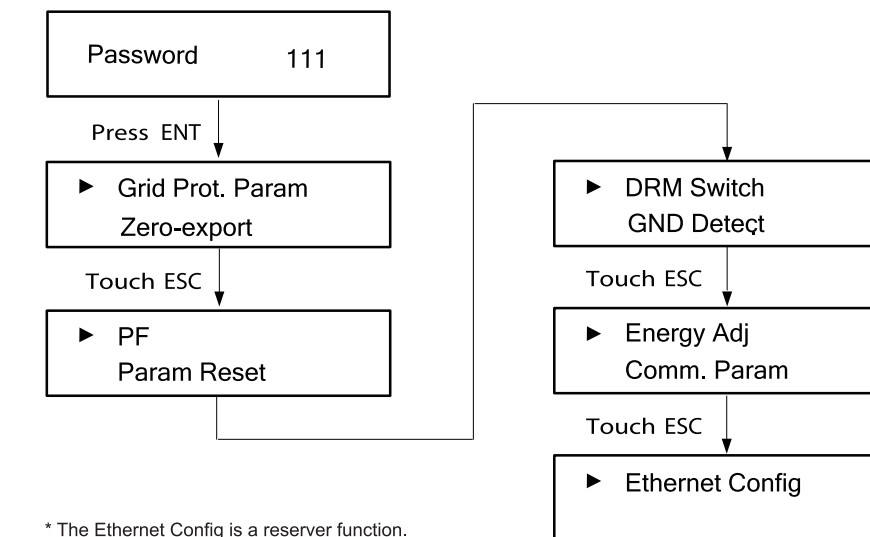

* The Ethernet Config is a reserver function.

5 FAQs

Tab. 5-1 Troubleshooting for some error codes

No.	Question	Answer
1	Fault 002-005	The local grid power's voltage fluctuated, which exceeds the permissible range. Please check the Vac [V] value shown on the LCD and contact Sungrow.
2	Fault 008 or 009	The local grid power's frequency fluctuated, which exceeds the permissible range. Please check the F [Hz] value shown on the LCD and contact Sungrow.
3	Fault 010	This is an "islanding" fault, which indicates the inverter could not detect the grid power. Please ensure all AC circuit breakers are rotated to "ON". If an issue persists, contact Sungrow.
4	Fault 106	This is an earth fault. Please contact your installer to check your solar system.
5	Fault 074	This is a LCD communication error. Please softly disconnect the RJ45 terminal and reconnect it. If an issue persists, contact Sungrow.

Refer to the user manuals of the inverter and the communication modules for details.